

A DISCUSSION ON THE CAUSES AND EFFECTS OF THERMAL AVALANCHE IN ARTIFICIAL SATELLITE BATTERY CHARGING AND DISCHARGING SYSTEMS

Renato Oliveira de Magalhães

Instituto Nacional de Pesquisas Espaciais,
Aerospace Electronics Division,
Av. dos Astronautas, 1758 São José dos Campos, SP Brasil (12) 3208 6221,
renato@dea.inpe.br

Marcelo Lopes de Oliveira e Souza

Instituto Nacional de Pesquisas Espaciais,
Mechanics and Control Division,
Av. dos Astronautas, 1758 São José dos Campos, SP Brasil (12) 3208 6201,
marcelo@dem.inpe.br

Abstract: *The supply of electrical power is one of the most important functions required by the diverse payloads of satellites. A fault in the corresponding subsystem might lead to mission or even vehicle loss. Among the causes of such faults, we highlight the phenomenon of thermal avalanche in batteries. It can be explained as an energetic unbalance where the rate of heat generated in the interior of the system exceeds its capacity to dissipate it. This occurred to the OAO1 of NASA just after its launch on April 8, 1966; and with the CBERS2 of CAST and INPE already in orbit in 2007 and 2009. This work presents a discussion on the causes and effects of thermal avalanches in artificial satellite battery charging and discharging systems. To do so it: 1) revises the literature on the known causes and effects; 2) develops a block diagram model for a battery charging and discharging system in artificial satellites, based on macroscopic principles which can be generalized to a wide variety of topologies and technologies of power supply and batteries; 3) discusses new causes and effects. Such discussion allows: 1) explains the thermal avalanche occurred to OAO1 and CBERS2; 2) estimate whether this will occur or not to other similar satellites as the CBERS3e4.*

Keywords: *Battery, Thermal Avalanche, Power Conditioning.*

1 Introduction

Brazil has been developing, over the years, remote sensing satellites to generate images for applications in important fields such as deforestation control, agriculture, urban development, soil utilization, just to name a few. They are inserted in a polar low Earth orbit, around 800km of altitude, taking roughly 90 minutes to complete a revolution around the planet, from which 60 minutes is spent in sunlight and the remaining time, in eclipse. To provide uninterrupted electrical power to the various spacecraft payloads CBERS satellites uses what is called hybrid topology (Sullivan, 2001), as shown in Figure 1. During sunlight, a regulated main bus voltage is provided at the output of the SHUNT equipment. Part of the Solar Array Generator (SAG) supplies the main bus load by means of a direct (high efficiency) transfer through SHUNT and the other fraction of SAG is used to recharge the battery by the Battery Charge and Heating Controller (BCHC) which is also responsible to provide heating power to the batteries. During eclipse, the Battery Discharging Regulator (BDR) regulates the main bus voltage, taking power from the batteries. The main bus power is distributed to the various spacecraft loads by DC/DC converters.

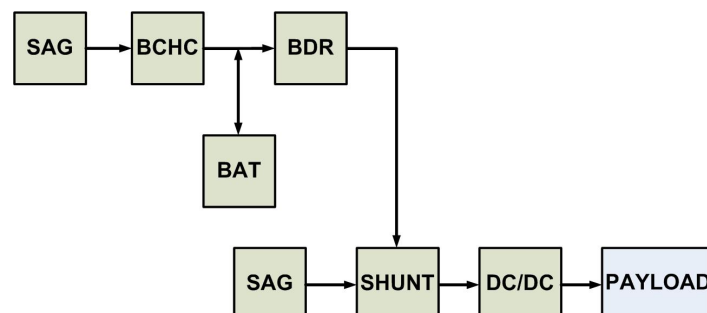

Figure 1: Power supply system block diagram.

It can happen that for some conditions that will be explained later, the charging and discharging process of the battery can cause overcharge that might lead to a type of system instability, characterized by a thermal avalanche which happened in the past in important NASA[2] and ESA[3] spacecraft and, in recent times, with CBERS2 satellite after it had completed its mission lifetime. This failure can increase battery temperature for a certain period and have no major effects if one brakes this vicious cycle or it becomes a catastrophic event in situations where the battery case explodes due to over gassing. In this case, mission is degraded or even interrupted. Therefore, to understand this mechanism, and find a way to prevent it, is of primordial interest for engineers in charge to design such systems.

References

Sullivan, D.O., 1989, "Satellite Power System Topologies", ESA Journal, vol.13, pp.77-88, 1989.